

SmartTWO

Smart level 2 charging station for public and commercial applications

The SmartTWO charging station is designed for public locations subject to harsh weather and vandalism.

Benefits

- Unique locking mechanism to protect the connector (U.S. Pat. No. 9,421,878B2); door unlocks on authentication
- Rugged and reliable design able to withstand harsh weather

Smart Charging Solution

- **Enhanced charging station owner experience** – Complete remote management capabilities including software and firmware updates
- **Enhanced user experience** – Deliver real-time updates and notifications to drivers
- **Revenue generation** – Implement payment services to generate revenue.
- **Access control** – Configure stations to authorize access using the FLO mobile app or RFID card authentication

Key features

- 3R enclosure type aluminum casing
- Certified to operate in temperatures ranging from -40 °C to 50 °C / -40 °F to 122 °F
- Equipped with a charging cable that remains flexible at low temperatures
- Wall-mounted or pole-mounted configuration
- Modular design to facilitate the installation of additional units and maintenance
- Access provided free of charge or according to a usage fee
- LED status indicator
- Software-based field calibration to Meet California Type Evaluation Program requirements

Overview

The SmartTWO charging stations are designed for outdoor / indoor vandal-prone public areas, or any place where robustness, durability and access control systems are critical. The SmartTWO is a user-friendly connected charging station that allows comprehensive and easy access to data via centralized information management software and can also generate revenue through usage fees.

Patented locking mechanism for maximum protection

The SmartTWO comes with a patented door locking mechanism. This means the mechanism unlocks only when a user authenticates, otherwise the door will remain closed. The connector will remain safe from vandals and will not be damaged from bad weather.

Physical features

- Rugged charging station able to withstand extreme weather and corrosion
- Thick and sturdy casing
- Universal SAE J1772 connector
- Flexible 25-foot cable that remains malleable even during winter's coldest temperatures

Applications

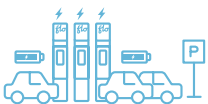

Commercial parking lots

- For business owners wanting to provide their customers with charging stations
- For businesses wanting to offer first class customer experience and become a destination of choice.
- For business owners who want to demonstrate their sustainable development leadership



Workplace

- For employers that want to provide their employees with a monitored charging service in a vandal-prone area

Available configurations



Wall-mounted



Double wall-mounted



Single pole-mounted



Double pole-mounted

Dimensions and customization

1

Every charging station includes easily customizable branding areas. The SmartTWO comes in its original colour, which can be modified with your custom signage.

Customizable partner panel area:

Dimensions (H x W):
500 mm (19.7") x 152.4 mm (6")

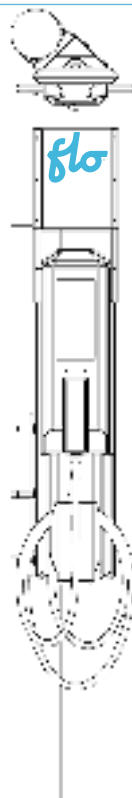

1

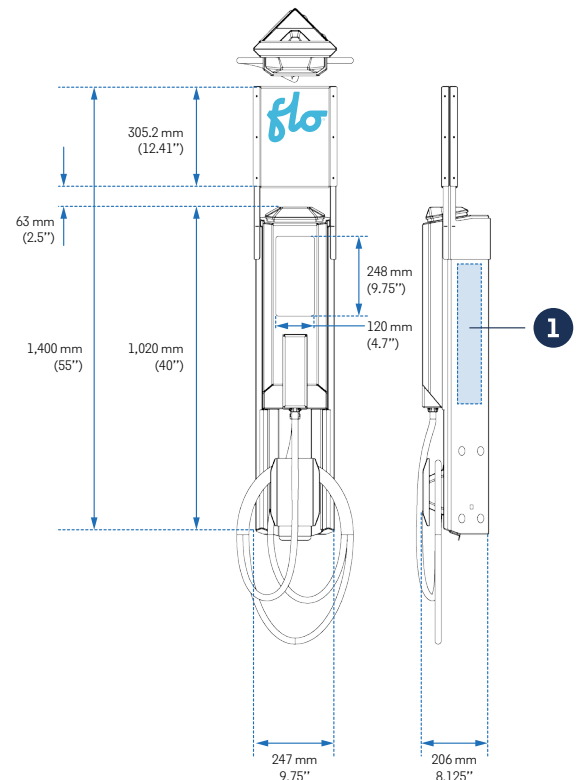

1

Technical specifications

Aluminum casing	3R enclosure type
Charging connector	SAE J1772
Cable	7.62 m / 25' Ultra Flex
Electrical load	30 A @ 208 VAC or 240 VAC
Charging power	Up to 7.2 kW
Output current	30 A
Integrated GFCI	20 mA, auto reset (3 attempts at 15-minute intervals)
Frequency	60 Hz
Operating and storage temperature	-40 °C to 50 °C / -40 °F to 122 °F
Weight	Wall-mounted configuration: 20 kg / 45 lb Pole-mounted configuration: 27 kg / 59 lb
Humidity	Up to 95% (non-condensing)
Card reader	ISO 14443 A/B, ISO 15693, RFID
Communication interface	ZigBee - IEEE 802.15.4 meshed network
Networking	Cellular - LTE (gateway is installed separately for optimal performances)
Certifications	CSA certified for Canada and United States Complies with UL 2594, UL 2231-1, UL 2231-2
EMC Compliance	USA - FCC 47 CFR 15, class A CAN - ICES-3 (A) / NMB-3 (A)
Metering Accuracy	Certified according to California Type Evaluation Program (CTEP)



Learn more
info@flo.com
 1 (855) 543-8356
flo.com



Designed and manufactured by AddÉnergie
 Technologies Inc. d/b/a FLO.